



STATE RESEARCH CENTER OF RUSSIA  
INSTITUTE FOR HIGH ENERGY PHYSICS

IHEP 98-34

A.G.Afonin, A.A.Arhipenko, V.I.Baranov, V.M.Biryukov,  
Yu.A.Chesnokov, V.A.Gavrilushkin, V.N.Gres, V.I.Kotov,  
V.A.Maishev, A.V.Minchenko, V.I.Terekhov,  
E.F.Troyanov, V.A.Zelenov

*Institute for High Energy Physics, Protvino*

B.A.Chunin, A.S.Denisov, M.G.Gordeeva, Yu.M.Ivanov,  
A.A.Petrinin, V.V.Skorobogatov

*Petersburg Nuclear Physics Institute*

**HIGH-EFFICIENCY MULTIPASS EXTRACTION  
OF 70 GEV PROTONS FROM ACCELERATOR  
WITH A SHORT BENT CRYSTAL**

Protvino 1998

**Abstract**

Afonin A.G. et al. High-efficiency multipass extraction of 70 GeV protons from accelerator with a short bent crystal: IHEP Preprint 98-34. – Protvino, 1998. – p. 6, figs. 2, refs.: 13.

Using channeling in a 5-mm crystal with a bending angle of 1.5 mrad, a radical increase in the efficiency of beam extraction from the accelerator was achieved due to an increased number of particle encounters with crystal. The measured world-highest efficiency of crystal extraction, over 40%, is in good agreement with theory predictions. The extracted beam intensity of  $6 \times 10^{11}$  ppp was obtained, five orders of magnitude higher than with the previous results.

**Аннотация**

Афонин А.Г. и др. Высокоэффективный многооборотный вывод 70 ГэВ протонов из ускорителя с помощью короткого изогнутого кристалла: Препринт ИФВЭ 98-34. – Протвино, 1998. – 6 с., 2 рис., библиогр.: 13.

Благодаря применению короткого кристалла длиной 5 мм, изогнутого на небольшой угол 1.5 мрад, достигнуто радикальное увеличение эффективности вывода пучка из ускорителя, связанное с увеличением среднего числа прохождений частиц через кристалл. Экспериментально достигнута эффективность вывода частиц более 40%, согласующаяся с данными теории. Получена рекордная величина интенсивности выведенного пучка до  $6 \times 10^{11}$  протонов за цикл, на 5 порядков выше предыдущих результатов.

## Introduction

Bent single crystals were successfully applied for beam extraction from accelerators, including the largest modern colliders [1,2,3]. At IHEP the bent crystals are routinely used for proton extraction to the beamlines originally designated for negative particles [4,5]. The obtained experimental data and theoretical analysis [6] show that the crucial factor for the efficiency of extraction is the multiplicity of beam particle encounters with crystal. This originates from the very low primary impact parameters, fraction of  $\mu\text{m}$ , of particles incident on the crystal on the first turn, while the nearsurface disrupted layer of crystal is several  $\mu\text{m}$  thick [7]. To overcome the layer inefficient for channeling, and to boost the extraction efficiency, one must enhance the multiplicity of particle encounters with crystal by reducing its length [8,9]. To research this mode of extraction at the IHEP 70 GeV proton synchrotron, we used a short crystal Si(110), 5 mm along the beam direction, with bending angle of 1.5 mrad.

## 1. Experiment

The bending of a short crystal in the accelerator environment is not easy. Our first test used a short crystal plate of a big height bent with a metal holder. Despite an angular distortion – a "twist" – in that design, the encouraging results on beam extraction were obtained [10]. Now, we used further, more promising technology for a crystal deflector without a twist. Unlike the CERN SPS experiment with "U-shaped" crystals [1], our crystal was cut from a monolithic piece in "O" shape at the St.Petersburg Nuclear Physics Institute. The bend was created by compressing the crystal in its middle part (Fig. 1a). The size of working zone of the crystal was  $0.6 \times 5 \times 5 \text{ mm}^3$  (thickness, height, and length along the beam direction, respectively). The bent part was 3 mm long, and the straight ends were 1 mm each.

The schematics of a beam extraction by crystal is shown in Fig. 1b. A deflection at 1.5 mrad is insufficient for a direct extraction from the accelerator. Therefore the crystal served as a primary element in the existing scheme of slow extraction. The crystal was

placed in straight section 19 of the accelerator before the septum-magnet OM-20 of the slow-extraction system; the OM-20 partition thickness was  $\sim 8$  mm (Fig. 1b). A local distortion of the orbit by means of bump magnets moved the beam toward the crystal positioned at 60-65 mm from the equilibrium orbit. The station of crystal septum has gears of horizontal and angular translation with accuracies of 0.1 mm and  $13.5 \mu\text{rad}$ , respectively. As both channeling regime and the extracted beam characteristics depend essentially on the circulating beam parameters, before experimenting with a crystal, we have measured the accelerator beam characteristics. Its horizontal emittance was  $2\pi$  mm $\times$ mrad, with the beam divergence at the crystal location of  $\pm 0.5$  mrad.

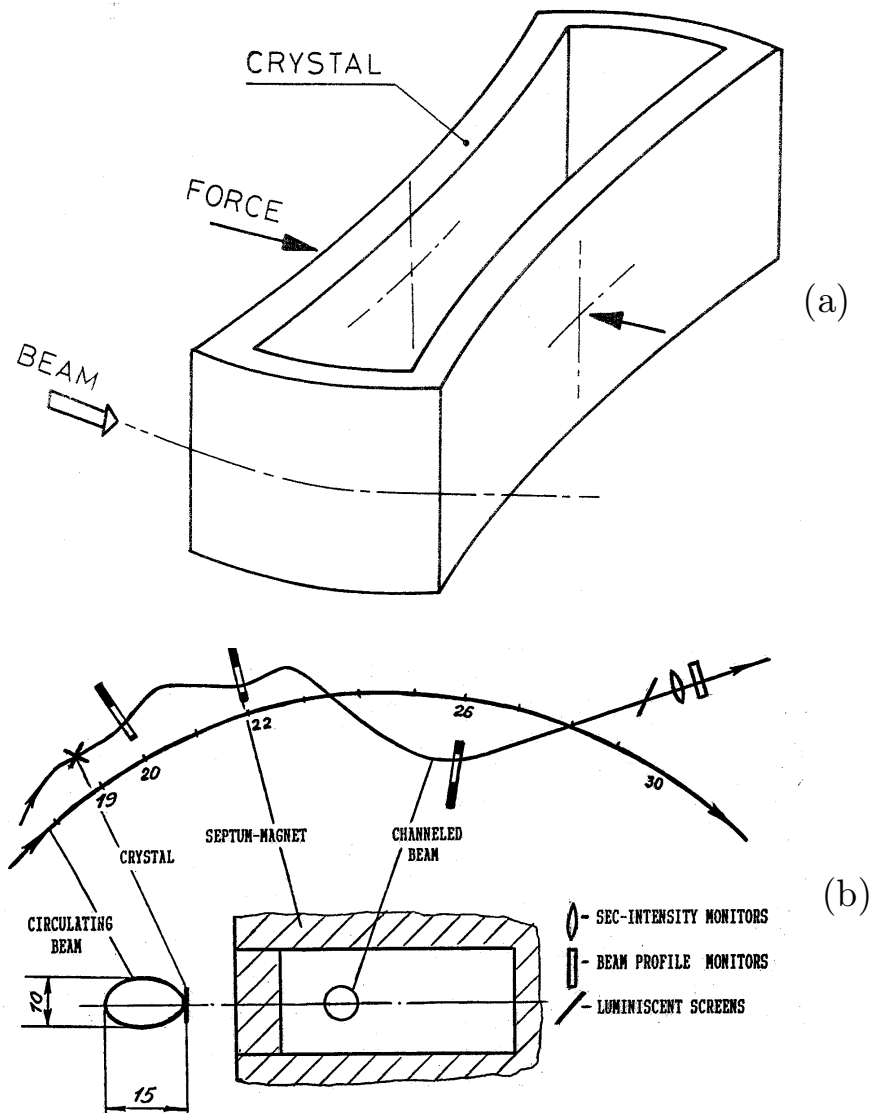

Fig. 1. (a) Schematics of the O-shaped crystal bending.  
 (b) Schematics of the experiment; the dimensions are in mm's.

The beam deflection to the aperture of OM-20 and its transmission through the beam line of extraction were supervised with a complex system of beam diagnostics, including TV system, loss monitors, profilometers, intensity monitors. All the diagnostics devices were firstly tested in the fast extraction mode and calibrated in a wide range of intensity. To obtain a flat rate of the beam at crystal, a monitor for close loop operation based on a photomultiplier with scintillator was used to automatically control the orbit distortion. This feedback monitor was placed at the orbit level, 10 m downstream of the crystal. The overall band of frequencies of the feedback line was 10 kHz.

## 2. Results

The beam store in the accelerator during the experiment was from  $1 \times 10^{12}$  to  $3 \times 10^{12}$  protons per cycle. The fraction of the beam store incident on the crystal was varied from 16 to 92%. The direct proof that the extracted beam was channeled, is the so called angular scan – the dependence of the extracted beam intensity on the orientation of the crystal. Fig. 2a (bottom) shows the measured scan in comparison with simulation results. Fig. 2a (top) shows the reduction in the beam store as a function of the crystal orientation, under conditions of the feedback system when the nuclear interaction rate at the crystal remains constant. This also proves a high efficiency of extraction (the channeled beam does not affect the feedback monitor!). The extraction efficiency can be evaluated also from this plot as  $(I_{max} - I_{min})/I_{max}$  and is equal to 36%, matching well the directly measured efficiency of 32% in this case. The temporal characteristics of extraction process are shown in Fig.2b (a digitizing oscilloscope recorded the circulating beam (1) and extracted beam (2) intensities). The spill duration of the channeled beam in the feedback regime was varied from 0.6 to 1.3 s. The plateau of the IHEP U-70 accelerator magnet cycle is 2 s long while the overall cycle of the machine is 9.6 s.

The main experimental task was to determine the extraction efficiency, defined as the ratio of extracted beam to reduction in the beam store. We measured both the efficiency averaged over a spill, and the efficiency as a function of time. Fig. 2c shows the measured efficiency, spill-averaged, for several beam intensities at the crystal, with the corresponding results from simulation. The highest efficiency of extraction,  $42 \pm 2\%$ , was obtained for a small fraction, 23%, of the beam store directed onto the crystal. With increasing the beam store fraction taken from the accelerator, the averaged-over-spill efficiency decreases, in agreement with computations, because of a significant drift (0.3 mrad) of the proton incidence angle at the crystal as the beam moves radially toward the crystal. For the same reason the extraction efficiency varies in time during the spill (Fig. 2b), especially for a large beam fraction used. Notably, the peak extraction efficiency in a spill was the same,  $47 \pm 3\%$ , irrespective of the beam store fraction.

The highest intensity of the extracted beam, for  $2.2 \times 10^{12}$  protons incident at the crystal in a cycle, was equal to  $6 \times 10^{11}$ , which is 5-6 orders of magnitude higher than the previous results [1-5]. The crystal worked in hard regime several days. It had an estimated temperature of several hundred degrees C but retained the same high channeling efficiency. The extracted beam was delivered by a magnet beamline to a particle physics experiment

with the beam spot size on a target of  $4 \times 4 \text{ mm}^2$  FWHM. The results, in particular the efficiency figures, were well reproducible throughout the entire experiment.

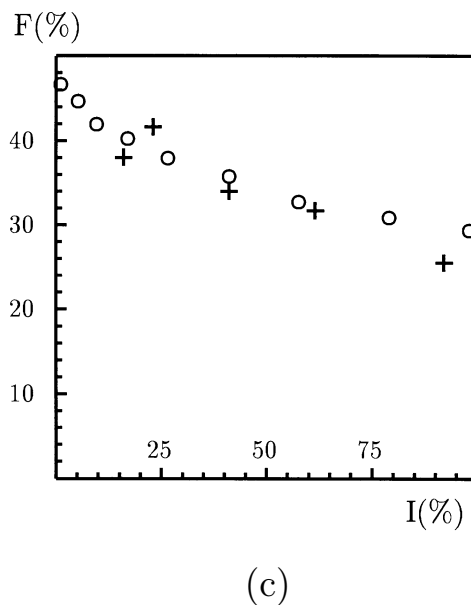
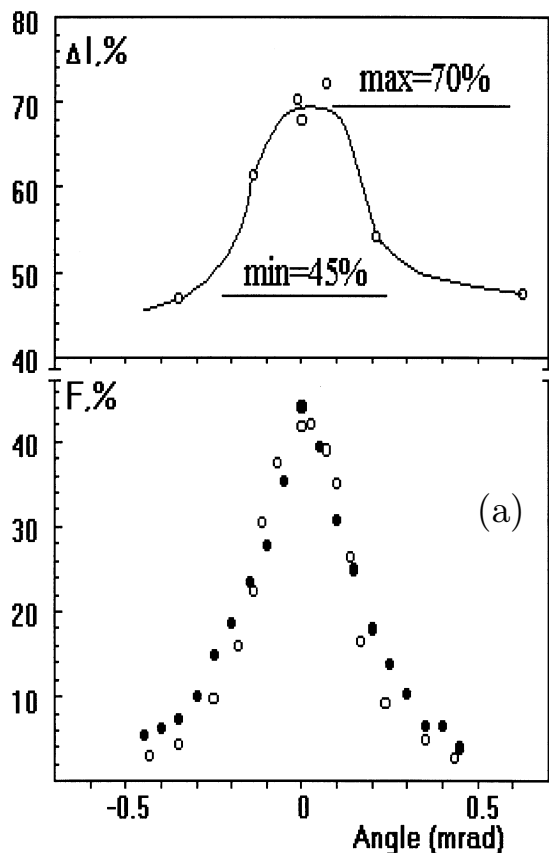
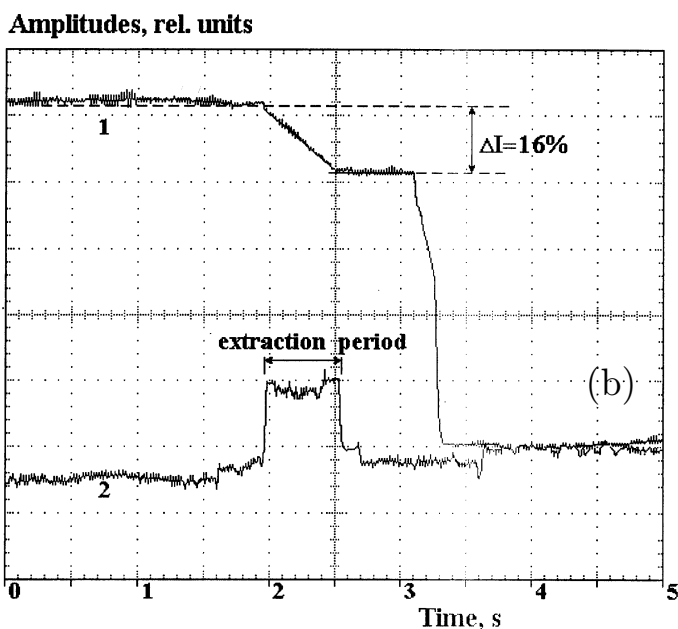

Fig. 2. (a) Bottom: the extraction efficiency as a function of the crystal angle; the measurements (open circles) and simulations (dots). Top: the reduction in the beam store as a function of the crystal angle under conditions of a feedback system.



(b) The time dependence of extraction: the circulating beam (1) and extracted beam (2) intensities.

(c) Efficiency of crystal extraction as a function of the beam store fraction incident on the crystal; the measurements (crosses) and simulations (open circles).

As the internal targets are widely used at the IHEP accelerator, one of practical ways to apply crystal is to ensure a proton beam extraction simultaneously with the work of one or two internal targets. Such a regime is quite complicated because of the mutual influence of bump systems, and because of deformation of beam phase portrait in interaction with the targets. We have performed a successful experiment on the crystal simultaneous work with one beryllium internal target.

### 3. Simulations

Computer simulation of the experiment was performed in advance [11] in order to find the optimum size of a crystal, to evaluate the influence on the efficiency of various parameters and to check the theory. The model took into account a real geometry of the crystal. The crystal lattice was considered ideal, however an amorphous layer some  $\mu\text{m}$  thick was simulated on the crystal surface. The initial impact parameter of  $<1 \mu\text{m}$ , thus, excluded the channeling at the particle first passage of a crystal. The simulation tracked any particle through a crystal and accelerator many turns until it was extracted or lost in a nuclear interaction at the crystal or at the aperture [12]; the results are reported in Fig. 2. This simulation has revealed that the extraction efficiency is insensitive to the amorphous layer thickness: the thickness variation in the range of 1 to 60  $\mu\text{m}$  produced only a 2-5% change in the efficiency; same insensitivity was earlier shown in the simulations for the CERN SPS experiments (p.150 in Ref.[7]).

In simulation we have found that the average number  $\langle N \rangle$  of passages through a crystal for particles of the extracted beam is much greater than 1, about 10, while an average number of passages before a nuclear interaction in crystal is about 60. The importance of  $\langle N \rangle$  factor in our experiment can be explained as follows. The efficiencies in the three major crystal extraction experiments (at CERN SPS, Fermilab Tevatron, and IHEP) look now comparable. However, at the SPS the efficiency was measured with a beam r.m.s. divergence  $\sigma$  at crystal smaller than Lindhard angle  $\theta_L$  (a critical angle for channeling), and at the Tevatron one had  $\sigma \simeq 2\theta_L$  [1,2]. In our conditions, the divergence of the beam circulating in the IHEP accelerator was  $\simeq 20$  times greater than  $\theta_L$  ( $\simeq 20\mu\text{rad}$  at 70 GeV), so only a few percent of the beam particles satisfied the channeling criteria in a single passage. The high overall efficiency of extraction was essentially due to the high multiplicity of proton encounters with the crystal.

### Conclusions

Our first experimental results are in very good agreement with theoretical predictions, which foresee an extraction efficiency of 70-90% at high-energy accelerators and colliders with the use of short crystals [12]. Such efficiency makes the crystal applications very promising for beams collimation [13] and extraction.

## Acknowledgements

The authors express their deep gratitude to A.A.Logunov and N.E.Tyurin for the support of this work. The work was supported by the Russian Foundation for Basic Research, grant no. 98-02-16941.

## References

- [1] H.Akbari et al., *Phys. Lett.* **B 313** (1993), 491.
- [2] C.T. Murphy et al., *Nucl. Instr. and Meth.* **B 119** (1996), 231.
- [3] G. Arduini, K. Elsener, G. Fidecaro et al., Proc. of Part. Accel. Conf., Vancouver (1997).
- [4] A.A.Asseev et al., *Nucl. Instr. and Meth. A* **309** 1 (1991).
- [5] V.M.Biryukov, V.N. Chepegin, Yu.A. Chesnokov et al., Proc. of Part. Accel. Conf., Vancouver (1997).
- [6] V.Biryukov, C.T. Murphy. Fermilab TM-2026, Batavia (1997).
- [7] V.M. Biryukov, Yu.A. Chesnokov and V.I. Kotov, "Crystal Channeling and its Application at High Energy Accelerators" (Berlin: Springer, 1997).
- [8] V.M. Biryukov, *Nucl. Instr. and Meth.* **B53** 202 (1991).
- [9] A.M. Taratin et al., *Nucl. Instr. and Meth. B* **58** 103 (1991).
- [10] A.G.Afonin et al., *JETP Lett.* **67**, No.10 (1998).
- [11] V.Biryukov. Invited talk at the 'Near Beam Physics' Symposium. Fermilab, Batavia (1997), in press.
- [12] V.M. Biryukov, *Phys. Rev.* **E 51**, 3522 (1995); **E 52**, 2045 (1995); **E 52**, 6818 (1995); *Phys. Rev. Lett.* **74**, 2471 (1995).
- [13] D.Trbojevic, V.Biryukov, M.Harrison, A.Stevens, N.Mokhov, A.Drozhdin. "A Study of the RHIC Crystal Collimation", contributed to EPAC (Stockholm, 1998).

*Received May 21, 1998*



А.Г.Афонин и др.

Высокоэффективный многооборотный вывод 70 ГэВ протонов из ускорителя с помощью короткого изогнутого кристалла.

Оригинал-макет подготовлен с помощью системы  $\text{\LaTeX}$ .

Редактор Е.Н.Горина.

Технический редактор Н.В.Орлова.

---

Подписано к печати 25.05.98. Формат  $60 \times 84/8$ .      Офсетная печать.  
Печ.л. 0,75.    Уч.-изд.л. 0,58.    Тираж 180.    Заказ 169.    Индекс 3649.  
ЛР №020498 17.04.97.

---

ГНЦ РФ Институт физики высоких энергий  
142284, Протвино Московской обл.

