

# OBSERVATIONAL FEATURES OF BLACK HOLES

A.F. Zakharov<sup>1,2\*</sup>, A.A. Nucita<sup>3</sup>, F. DePaolis<sup>3</sup>, G. Ingresso<sup>3</sup>

<sup>1</sup>*Institute of Theoretical and Experimental Physics, Moscow, Russia.*

<sup>2</sup>*Space Research Centre of Lebedev Physics Institute, Moscow.*

<sup>3</sup>*Dipartimento di Fisica Universita di Lecce and INFN, Sezione di Lecce, Italy.*

Recently Holz & Wheeler [59] considered a very attracting possibility to detect retro-MACHOs, i.e. retro-images of the Sun by a Schwarzschild black hole. In this paper we discuss glories (mirages) formed near rapidly rotating Kerr black hole horizons and propose a procedure to measure masses and rotation parameters analyzing these forms of mirages. In some sense that is a manifestation of gravitational lens effect in the strong gravitational field near black hole horizon and a generalization of the retro-gravitational lens phenomenon. We analyze the case of a Kerr black hole rotating at arbitrary speed for some selected positions of a distant observer with respect to the equatorial plane of a Kerr black hole. We discuss glories (mirages) formed near rapidly rotating Kerr black hole horizons and propose a procedure to measure masses and rotation parameters analyzing these forms of mirages. Some time ago Falcke, Melia & Agol [60] suggested to search shadows at the Galactic Center. In this paper we present the boundaries for shadows calculated numerically. We also propose to use future radio interferometer RADIOASTRON facilities to measure shapes of mirages (glories) and to evaluate the black hole spin as a function of the position angle of a distant observer.

## 1. Introduction

More than ten years ago it was predicted that profiles of lines emitted by AGNs and X-ray binary systems<sup>1</sup> could have an asymmetric double-peaked shape (e.g. [4, 5, 6]). Generation of the broad  $K_\alpha$  fluorescence lines as a result of irradiation of a cold accretion disk was discussed by many authors (see, for example, [7, 8, 9, 10, 11, 12] and references therein). Popovic et al. [13, 14] discussed influence of microlensing on the distortion of spectral lines including Fe  $K_\alpha$  line, that can be significant in some cases. Zakharov et al. [15, 16, 17] showed that the optical depth for microlensing could be significant for cosmological distributions of microlenses. Recent X-ray observations of Seyfert galaxies, microquasars and binary systems ([18, 19, 20, 21, 22, 23, 24, 25, 26] and references therein) confirm these considerations in general and reveal broad emission lines in their spectra with characteristic two-peak profiles. A comprehensive review by Fabian et al. [27] summarizes the detailed discussion of theoretical aspects of possible scenarios for generation of broad iron lines in AGNs. These lines are assumed to arise in the innermost parts of the accretion disk, where the effects of General Relativity (GR) must be taken into account, otherwise it appears very difficult to find a natural explanation for observed line profile.

Numerical simulations of the line structure are be found in a number of papers [11, 28, 29, 30, 31, 32, 33, 34, 35, 36, 37, 38]. They indicate that the accretion disks in Seyfert galaxies are usually observed at the inclination angle  $\theta$  close to  $30^\circ$  or less. This occurs because according to the Seyfert galaxy models, an opaque dusty torque surrounds the accretion disk which does not allow us to observe the disk at larger inclination angles.

---

\*E-mail: zakharov@itep.ru

<sup>1</sup>Some of them are microquasars (for details see, for example, [1, 2, 3]).

However, at inclination angles  $\theta > 80^\circ$ , new observational manifestations of GR could arise. (Matt, Perola & Stella [6] discovered such phenomenon for a Schwarzschild black hole, moreover the authors predicted that their results could be applicable to a Kerr black hole over the range of parameters exploited). The authors mentioned that this problem was not analyzed in detail for a Kerr metric case and it would be necessary to investigate this case. Below we do not use a specific model on surface emissivity of accretion (we only assume that the emitting region is narrow enough). But general statements (which will be described below) can be generalized to a wide disk case without any problem. Therefore, in this paper we check and confirm their hypothesis for the Kerr metric case and for a Schwarzschild black hole using other assumptions about surface emissivity of accretion disks. In principle, such a phenomenon could be observed in microquasars and X-ray binary systems where there are neutron stars and black holes with stellar masses.

A mathematical tool to simulate spectral line shapes and results of simulations are published in papers [39, 40, 41, 42, 43, 44, 45, 46, 47, 48, 49, 50, 51, 52, 53, 54, 55]. The approach was used in particular to simulate spectral line shapes. For example, Zakharov et al. [55] used this approach to simulate the influence of a magnetic field on spectral line profiles. Recent review on the subject one could find in papers [57, 58].

Recently Holz & Wheeler [59] have suggested that a Schwarzschild black hole may form retro-images (called retro-MACHOs) if it is illuminated by the Sun. We analyze a rapidly rotating Kerr black hole case for some selected positions of a distant observer with respect to the equatorial plane of the Kerr black hole. We discuss glory (mirage) formed near a rapidly rotating Kerr black hole horizon and propose a procedure to measure the mass and the rotation parameter analyzing the mirage shapes. Since a source illuminating the black hole surroundings may be located in an arbitrary direction with respect to the observer line of sight, a generalization of the retro-gravitational lens idea suggested by Holz & Wheeler [59] is needed. A strong gravitational field approximation for a gravitational lens model was considered recently in several papers [61, 62, 63, 64, 65, 66, 68, 69, 70, 71, 72, 73]. However, if we consider the standard geometry for a gravitational lens model, namely if a gravitational lens is located between a source and observer, then the probability to have evidences for strong gravitational field effects is quite small, because the probability is about  $P \sim \tau_{GL} \times R_G/D_S$  where,  $\tau_{GL}$  is the optical depth for gravitational lensing and the factor  $R_G/D_S$  corresponds to a probability to have a manifestations for strong gravitational field effects ( $R_G$  is the Schwarzschild radius for a gravitational lens,  $D_S$  is a distance between an observer and gravitational lens). Therefore, the factor  $R_G/D_S$  is quite small for typical astronomical cases. However, these arguments cannot be used for the cases of a source located nearby a black hole.

First, it is necessary to explain differences of a considered geometry, standard geometry of gravitational lensing (when a gravitational lens is located roughly speaking between a source and an observer) and a model introduced by Holz & Wheeler [59] when an observer is located between a source (Sun) and a gravitational lens that is a black hole. In this paper we will consider images formed by retro-photons, but in contrast to Holz & Wheeler [59] we will analyze forms of images near black holes but not a light curve of an image formed near black hole as Holz & Wheeler [59] did. In our consideration a location of source could be arbitrary in great part (in accordance with a geometry different parts of images could be formed)<sup>2</sup>, for example, accretion flows (disks) could be sources forming such images. Since in such cases images formed by retro-photons are considered, we call it like retro gravitational lensing even if a source is located near a gravitational lens (a black hole) in contrast to a standard gravitational lens model.

The plan of the paper is as follows. In section 2 we discuss possible mirage shapes. In section 3 we analyze the most simple case of source and observer in the black hole equatorial plane. In

---

<sup>2</sup>However, if a source is located between black hole and an observer, images formed by retro-photons and located near black holes could be non-detectable.

section 4 we consider the case of observer at the rotation axis of a spinning black hole. In section 5 we consider observer in a general position with respect to the rotation axis. The basic characteristics of future space based radio interferometer RADIOASTRON were given in 6. In section 7 we discuss Sgr A\* as a possible target for RADIOASTRON observations to possibly observe such images near the black hole located in the object. In section 8 we discuss our results of calculations and in section 9 we present our conclusions.

## 2. Mirage shapes

As usual, we use geometrical units with  $G = c = 1$ . It is convenient also to measure all distances in black hole masses, so we may set  $M = 1$  ( $M$  is a black hole mass). Calculations of mirage forms are based on qualitative analysis of different types of photon geodesics in a Kerr metric (for references see [74, 75, 76, 77]). In fact, we know that impact parameters of photons are very close to the critical ones (which correspond to parabolic orbits). One can find some samples of photon trajectories in [39, 75]. This set (critical curve) of impact parameters separates escape and plunge orbits (see for details, [74, 75, 76, 77]) or otherwise the critical curve separates scatter and capture regions for unbounded photon trajectories). Therefore the mirage shapes almost look like to critical curves but are just reflected with respect to z-axis. We assume that mirages of all orders almost coincide and form only one quasi-ring from the point of view of the observer. We know that the impact parameter corresponding to the  $\pi$  deflection is close to that corresponding to a  $n\pi$  deflections ( $n$  is an odd number). For more details see [59] (astronomical applications of this idea was discussed by De Paolis et al. [78] and its generalizations for Kerr black hole are considered by De Paolis et al. [79]). We use prefix “quasi” since we consider a Kerr black hole case, so that mirage shapes are not circular rings but Kerr ones. Moreover, the side which is formed by co-moving (or co-rotating) photons is much brighter than the opposite side since rotation of a black hole squeeze deviations between geodesics because of Lense–Thirring effect. Otherwise, rotation stretches deviations between geodesics for counter-moving photons.

This assumption is based on estimates of differences of impact parameters for critical values and impact parameters corresponding to  $\pi$  deflection. Actually, following [59] we use the approximation  $b = b_c + b_d e^{-\Theta}$  for the impact parameter in the case of a Schwarzschild black hole, where  $\Theta$  is the deflection angle. For  $\pi$  deflection we will take into account the fact that it is possible to neglect the second term  $b_d e^{-\Theta} \approx 3.4823 e^{-\Theta} \approx 0.15$ , in comparison with the first one  $b = b_c = 3\sqrt{3} \approx 5.1962$ . The precision of such procedure (when we change impact parameter corresponding to  $\pi$  rotation by the critical impact parameter) is better than 3% (a precision of such procedure for co-moving (co-rotating) photons propagating near a rapidly spinning black hole is much higher). In spite of the fact that there are a number of other corrections to improve Luminet [80] approximation (see, for example [81, 66, 82]), the black hole spin effect gives a more important correction with respect to the improvement which can be obtained by improving Luminet [80] approximation. For example, if we want to consider large deflection angles, taking into account the influence of the black hole spin on impact parameters we conclude that the spin changes the result of a factor larger than 2.5 (since we have an impact parameter larger than 5.19 for a Schwarzschild metric and about 2 for the extreme Kerr metric). Note that corrections to Luminet [80] approximation can give only an improvement less than one percent.

We would like to mention that in connection with rapidly rotating neutron stars, some corrections to the Schwarzschild metric are necessary in order to analyze photon geodesic trajectories [81]. However, this procedure is not self-consistent since a rapidly rotating neutron star may have a rather high value of its ellipticity  $e = 1 - (a/b)$  [83, 84] (i.e. difference between equatorial and polar axes). Indeed, even Kerr metric is not the exact approximation near rapidly rotating neutron star

surface. In this case, like for black holes, rotation gives a more important corrections with respect to some modifications of [80] approximation.

The full classification of geodesic types for Kerr metric is given in [76]. As it was shown in this paper, there are three photon geodesic types: capture, scattering and critical curve which separates the first two sets. This classification fully depends only on two parameters  $\xi = L_z/E$  and  $\eta = Q/E^2$ , which are known as Chandrasekhar's constants [75]. Here the Carter constant  $Q$  is given by Carter [85]

$$Q = p_\theta^2 + \cos^2 \theta [a^2 (m^2 - E^2) + L_z^2/\sin^2 \theta], \quad (1)$$

where  $E = p_t$  is the particle energy at infinity,  $L_z = p_\phi$  is  $z$ -component of its angular momentum,  $m = p_i p^i$  is the particle mass. Therefore, since photons have  $m = 0$

$$\eta = p_\theta^2/E^2 + \cos^2 \theta [-a^2 + \xi^2/\sin^2 \theta]. \quad (2)$$

The first integral for the equation of photon motion (isotropic geodesics) for a radial coordinate in the Kerr metric is described by the following equation [85, 75, 76, 86]

$$\rho^4 (dr/d\lambda)^2 = R(r),$$

where

$$R(r) = r^4 + (a^2 - \xi^2 - \eta)r^2 + 2[\eta + (\xi - a)^2]r - a^2\eta, \quad (3)$$

and  $\rho^2 = r^2 + a^2 \cos^2 \theta$ ,  $\Delta = r^2 - 2r + a^2$ ,  $a = S/M^2$ . The constants  $M$  and  $S$  are the black hole mass and angular momentum, respectively. Eq. (3) is written in dimensionless variables (all lengths are expressed in black hole mass units  $M$ ).

We will consider different types of geodesics on  $r$  - coordinate in spite of the fact that these type of geodesics were discussed in a number of papers and books, in particular in a classical monograph by Chandrasekhar [75] (where the most suited analysis for our goals was given). However, our consideration is differed even Chandrasekhar's analysis in the following items.

i) Chandrasekhar [75] considered the set of critical geodesics separating capture and scatter regions as parametric functions  $\eta(r), \xi(r)$ , but not as the function  $\eta(\xi)$  (as we do). However, we believe that a direct presentation of function  $\eta(\xi)$  is much more clear and give a vivid illustration of different types of motion. Moreover, one could obtain directly form of mirages from the function  $\eta(\xi)$  (as it will be explained below).

ii) Chandrasekhar [75] considered the function  $\eta(r)$  also for  $\eta < 0$  and that is not quit correct, because for  $\eta < 0$  allowed constants of motion correspond only to capture (as it was mentioned in the book by [75]). This point will be briefly discussed below.

If we fix a black hole spin parameter  $a$  and consider a plane  $(\xi, \eta)$  and different types of photon trajectories corresponding to  $(\xi, \eta)$ , namely, a capture region, a scatter region and the critical curve  $\eta_{\text{crit}}(\xi)$  separating the scatter and capture regions. The critical curve is a set of  $(\xi, \eta)$  where the polynomial  $R(r)$  has a multiple root (a double root for this case). Thus, the critical curve  $\eta_{\text{crit}}(\xi)$  could be determined from the system [76, 86]

$$\begin{aligned} R(r) &= 0, \\ \frac{\partial R}{\partial r}(r) &= 0, \end{aligned} \quad (4)$$

for  $\eta \geq 0, r \geq r_+ = 1 + \sqrt{1 - a^2}$ , because by analyzing of trajectories along the  $\theta$  coordinate we know that for  $\eta < 0$  we have  $M = \{(\xi, \eta) | \eta \geq -a^2 + 2a|\xi| - \xi^2, -a \leq \xi \leq a\}$  and for each point  $(\xi, \eta) \in M$  photons will be captured. If instead  $\eta < 0$  and  $(\xi, \eta) \notin M$ , photons cannot have such constants of motion, corresponding to the forbidden region (see, [75, 76] for details).

One can therefore calculate the critical curve  $\eta(\xi)$  which separates the capture and the scattering regions [76, 86]. We remind that the maximal value for  $\eta_{\text{crit}}(\xi)$  is equal to 27 and is reached at  $\xi = -2a$ . Obviously, if  $a \rightarrow 0$ , the well-known critical value for Schwarzschild black hole (with  $a = 0$ ) is obtained.

Thus, at first, we calculate the critical curves for chosen spin parameters  $a$  which are shown in Fig. 1. The shape of the critical curve for  $a = 0$  (Schwarzschild black hole) is well-known because for this case we have  $\eta_{\text{crit}}(\xi) = 27 - \xi^2$  for  $|\xi| \leq 3\sqrt{3}$ , but we show the critical curve to compare with the other cases.

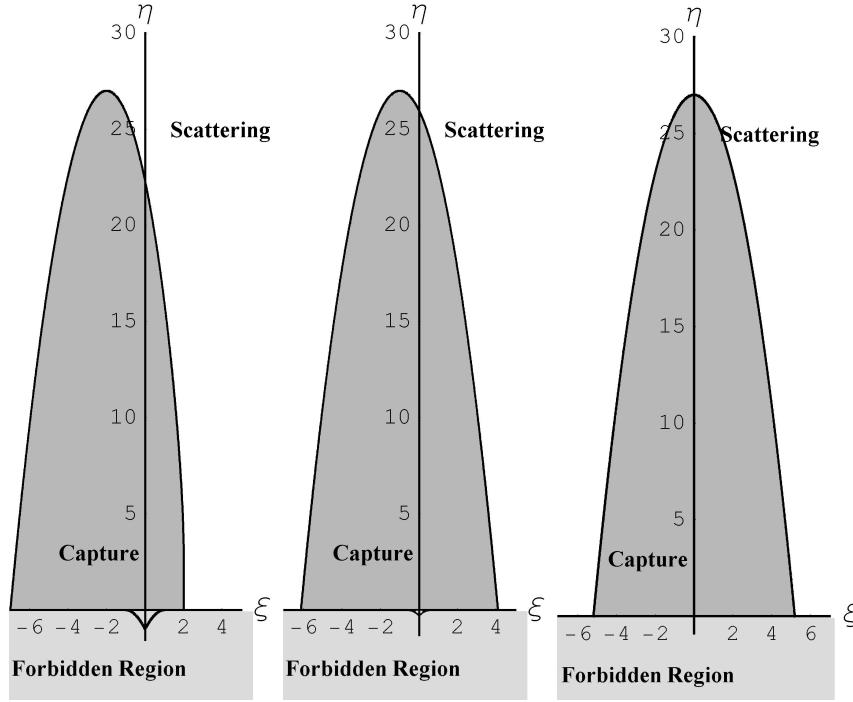

Fig. 1. Different types for photon trajectories and spin parameters ( $a = 1., a = 0.5, a = 0.$ ). Critical curves separate capture and scatter regions. Here we show also the forbidden region corresponding to constants of motion  $\eta < 0$  and  $(\xi, \eta) \in M$  as it was discussed in the text.

By following this approach we can find the set of critical impact parameters  $(\alpha, \beta)$ , for the image (mirage or glory) around a rotating black hole. The sets of critical parameters form caustics around black holes and it is well-known that caustics are the brightest part of each image (numerical simulations of caustic formations were done by Rauch & Blandford [87]). We remind that  $(\alpha, \beta)$  parameters could be evaluated in terms of  $(\xi, \eta_{\text{crit}})$  by the following way [75]

$$\alpha(\xi) = \xi / \sin \theta_0, \quad (5)$$

$$\begin{aligned} \beta(\xi) &= (\eta_{\text{crit}}(\xi) + a^2 \cos^2 \theta_0 - \xi^2 \cot^2 \theta_0)^{1/2} \\ &= (\eta_{\text{crit}}(\xi) + (a^2 - \alpha^2(\xi)) \cos^2 \theta_0)^{1/2}. \end{aligned} \quad (6)$$

Actually, the mirage shapes are boundaries for shadows considered by Falcke, Melia & Agol [60]. Recently, Beckwith & Done [88] calculated the shapes of mirages around black holes assuming that an accretion disk illuminates a Schwarzschild black hole.

Before closing this section, we note that the precision we obtain by considering critical impact parameters instead of their exact values for photon trajectories reaching the observer is good enough. In particular, co-rotating photons form much brighter part of images with respect to retrograde photons. Of course, the larger is the black hole spin parameter the larger is this effect (i.e. the co-rotating part of the images become closest to the black hole horizon and brighter).

This approximation is based not only on numerical simulation results of photon propagation [41, 89, 42, 43, 90, 54, 91, 92, 93] (about  $10^9$  photon trajectories were analyzed) but also on analytical results (see, for example [75, 76]).

### 3. Equatorial plane observer case

Let us assume that the observer is located in the equatorial plane ( $\theta = \pi/2$ ). For this case we have from Eqs. (5) and (6)

$$\alpha(\xi) = \xi, \quad (7)$$

$$\beta(\xi) = \sqrt{\eta_{\text{crit}}(\xi)}. \quad (8)$$

As mentioned in section 2, the maximum impact value  $\beta = 3\sqrt{3}$  corresponds to  $\alpha = -2a$  and if we consider the extreme spin parameter  $a = 1$  a segment of straight line  $\alpha = 2, 0 < |\beta| < \sqrt{3}$  belongs to the mirage (see images in Fig. 3. for different spin parameters). It is clear that for this case one could easily evaluate the black hole spin parameter after the mirage shape reconstruction since we have a rather strong dependence of the shapes on spins. As it was explained earlier, the maximum absolute value for  $|\beta| = \sqrt{27} \approx 5.196$  corresponds to  $\alpha = -2a$  since the maximum value for  $\eta(\xi)$  corresponds to  $\eta(-2a) = 27$  as it was found by Zakharov [76]. Therefore, in principle it is possible to estimate the black hole spin parameter by measuring the position of the maximum value for  $\beta$ , but probably that part of the mirage could be too faint to be detected.

### 4. Polar axis observer case

If the observer is located along the polar axis we have  $\theta_0 = 0$  and from Eq. (6) we obtain

$$\beta(\alpha) = (\eta_{\text{crit}}(0) + a^2 - \alpha^2(\xi))^{1/2}, \quad (9)$$

or

$$\beta^2(\alpha) + \alpha^2 = \eta_{\text{crit}}(0) + a^2. \quad (10)$$

Thus, mirages around Kerr black hole look like circles and even for this case in principle we could evaluate the black hole spin (if the black hole mass is known) taking into account that radii of these circles weakly depend on the black hole spin parameter. However, one should mention that due to the small difference between radii for different spins, even in the future it is unlikely to be able to measure black hole spins in this way (see Table 1).

**Table 1.** Dependence of  $\eta(0)$  and mirage radii  $R_{\text{circ}} = (\eta(0) + a^2)^{1/2}$  on spins.

$a$	0	0.2	0.4	0.5	0.6	0.8	1.
$\eta(0)$	27	26.839	26.348	25.970	25.495	24.210	22.314
$R_{\text{circ}}$	5.196	5.185	5.149	5.121	5.085	4.985	4.828

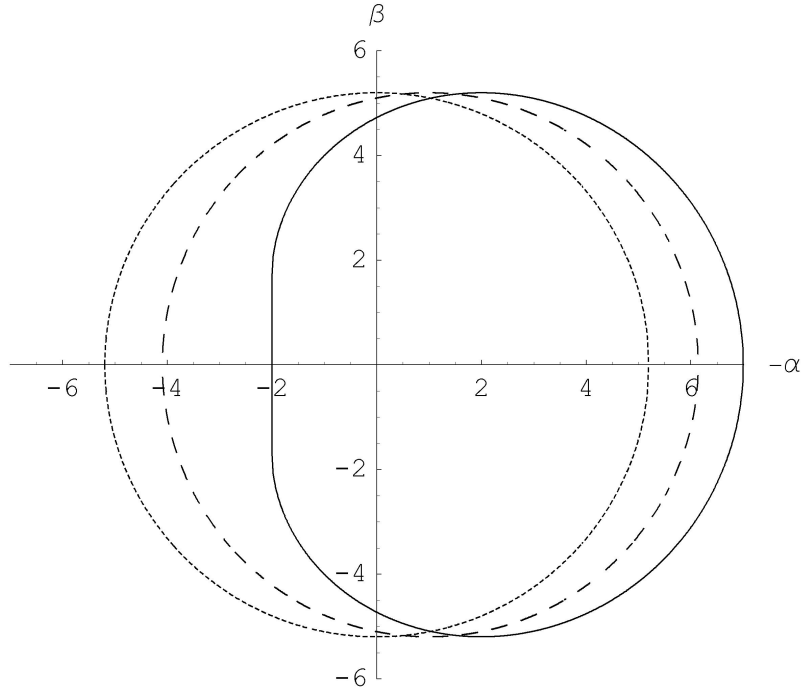

Fig. 2. Mirages around black hole for equatorial position of distant observer and different spin parameters. The solid line, the dashed line and the dotted line correspond to  $a = 1, a = 0.5, a = 0$  correspondingly.

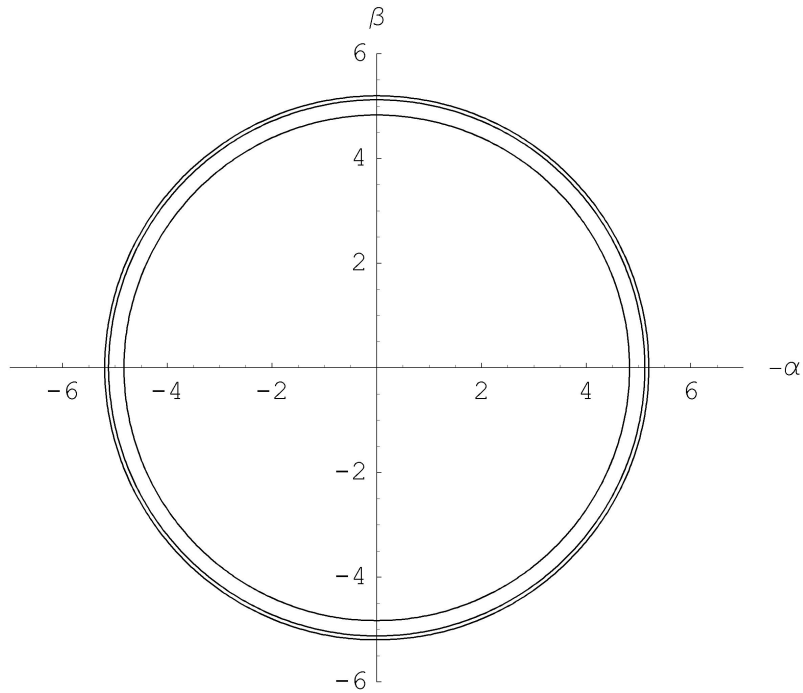

Fig. 3. Mirages around a black hole for the polar axis position of distant observer and different spin parameters ( $a = 0, a = 0.5, a = 1$ ). Smaller radii correspond to greater spin parameters.

## 5. General case for the angular position of the observer

Let us consider different values for the angular positions of a distant observer  $\theta = \pi/2, \pi/3$  and  $\pi/8$  for the spin parameter  $a = 0.5$  (Fig. 4) and  $\theta = \pi/2, \pi/3, \pi/4$  and  $\pi/6$  for  $a = 1$ . (Fig. 5). From these Figures one can see that angular positions of a distant observer could be evaluated from the mirage shapes only for rapidly rotating black holes ( $a \sim 1$ ), but there are no chances to evaluate the angles for slowly rotating black holes, because even for  $a = 0.5$  the mirage shape differences are too small to be distinguishable by observations. Indeed, mirage shapes weakly depend on the observer angle position for moderate black hole spin parameters.

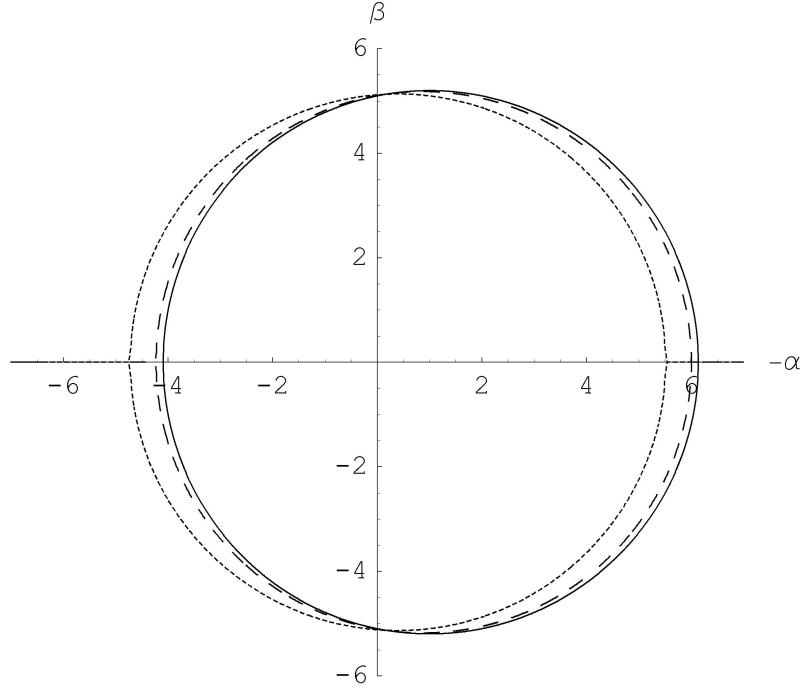

Fig. 4. Mirages around black hole for different angular positions of a distant observer and the spin  $a = 0.5$ . Solid, dashed and dotted lines correspond to  $\theta_0 = \pi/2, \pi/3$  and  $\pi/8$ , respectively.

## 6. Projected parameters of the space RADIOASTRON interferometer

During this decade the space radio telescope RADIOASTRON will be launched. This project was initiated by Astro Space Center (ASC) of Lebedev Physical Institute of Russian Academy of Sciences (RAS) in collaboration with other institutions of RAS and RosAviaKosmos. Scientists from 20 countries develop the scientific payload for the satellite and will provide a ground base support of the mission. The project was approved by RAS and RosAviaKosmos and is smoothly developing. This space based 10-meter radio telescope will be used for space-ground VLBI measurements. The measurements will have extraordinary high angular resolutions, namely about 1 – 10 microarcseconds (in particular about 8 microarcseconds at the shortest wavelength 1.35 cm and a standard orbit and could be about 0.9 microarcseconds for the high orbit at the same wavelength. For observations four wave bands will be used corresponding to  $\lambda = 1.35$  cm,  $\lambda = 6.2$  cm,  $\lambda = 18$  cm,  $\lambda = 92$  cm.



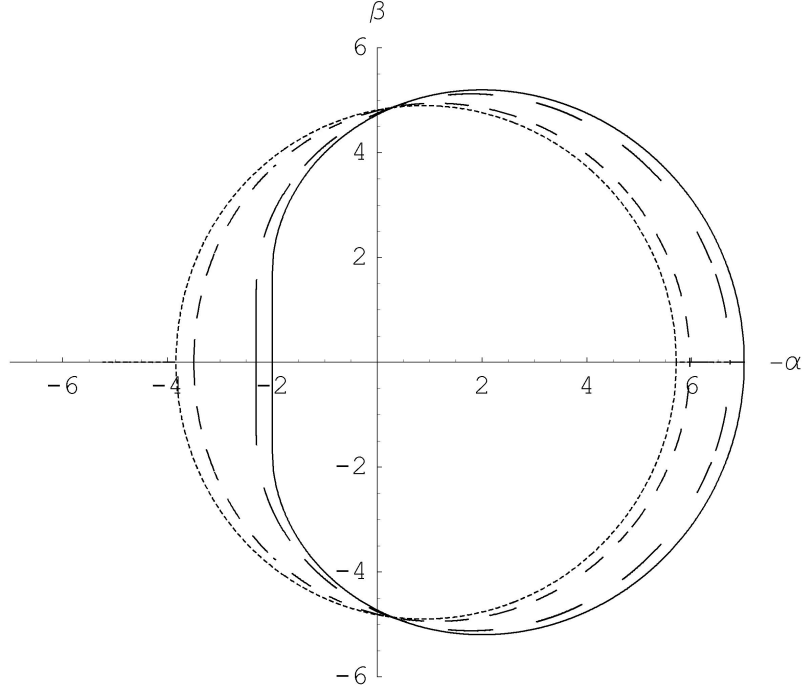

Fig. 5. Mirages around black hole for different angular positions of a distant observer and the spin  $a = 1$ . Solid, long dashed, short dashed and dotted lines correspond to  $\theta_0 = \pi/2, \pi/3, \pi/6$  and  $\pi/8$ , respectively.

An orbit for the satellite was chosen with high apogee and with period of satellite rotation around the Earth 9.5 days, which evolves as a result of weak gravitational perturbations from the Moon and the Sun. The perigee is in a band from 10 to 70 thousand kilometers, the apogee is a band from 310 to 390 thousand kilometers. The basic orbit parameters will be the following: the orbital period is  $p = 9.5$  days, the semi-major axis is  $a = 189\,000$  km, the eccentricity is  $e = 0.853$ , the perigee is  $H = 29\,000$  km.

A detailed calculation of the high-apogee evolving orbit can be done if the exact time of launch is known.

After several years of observations, it would be possible to move the spacecraft to a much higher orbit (with apogee radius about 3.2 million km), by additional spacecraft maneuver using gravitational force of the Moon. In this case it would be necessary to use 64–70 m antennas for the spacecraft control, synchronizations and telemetry<sup>3</sup>.

The fringe sizes (in micro arc seconds) for the apogee of the above-mentioned orbit and for all RADIOASTRON bands are given in Table 2.

Table 2. The fringe sizes (in micro arc seconds) for the standard and advanced apogees  $B_{max}$  (350 000 and 3 200 000 km correspondingly).

$B_{max}(\text{km}) \setminus \lambda(\text{cm})$	92	18	6.2	1.35
$3.5 \times 10^5$	540	106	37	8
$3.2 \times 10^6$	59	12	4	0.9

<sup>3</sup><http://www.asc.rssi.ru/radioastron/>

Thus, there are non-negligible chances to observe such mirages around the black hole at the Galactic Center and in nearby AGNs and microquasars in the radio-band using RADIOASTRON facilities.

We also mention that this high resolution in radio band will be achieved also by Japanese VLBI project VERA (VLBI Exploration of Radio Astrometry), since angular resolution will be at the  $10 \mu\text{as}$  level [94, 95, 96]. Therefore, there only a problem to have a powerful radio source to illuminate a black hole to be detectable by such radio VLBI telescopes like RADIOASTRON or VERA.

## 7. Searches of mirages near Sgr A\* with RADIOASTRON

Observations of Sgr A\* in radio, near-infrared and X-ray spectral bands develop very rapidly [97, 98, 99, 100, 101, 102, 103, 105, 104]<sup>4</sup> also because it harbours the closest massive black hole. The mass of this black holes is estimated to be  $4 \times 10^6 M_\odot$  [104, 107, 108, 109] and its intrinsic size from VLBA observations at wavelengths  $\lambda = 2 \text{ cm}, 1.3 \text{ cm}, 0.6 \text{ cm}$  and  $0.3 \text{ cm}$  [104].

Similarly to [60] we propose to use VLBI technique to observe the discussed mirages around black holes. They used ray-tracing calculations to evaluate the shapes of shadows. The boundaries of the shadows are black hole mirages (glories or “faces”) analyzed earlier. We use the length parameter  $r_g = \frac{GM}{c^2} = 6 \times 10^{11} \text{ cm}$  to calculate all values in these units as it was explained in the text. If we take into account the distance towards the Galactic Center  $D_{\text{GC}} = 8 \text{ kpc}$  then the length  $r_g$  corresponds to angular sizes  $\sim 5 \mu\text{as}$ . Since the minimum arc size for the considered mirages are about  $2r_g$ , the standard RADIOASTRON resolution of about  $8 \mu\text{as}$  is comparable with the required precision. The resolution in the case of the higher orbit and shortest wavelength is  $\sim 1 \mu\text{as}$  (Table 2) good enough to reconstruct the shapes. Therefore, in principle it will be possible to evaluate  $a$  and  $\theta$  parameters after mirage shape reconstructions from observational data even if we will observe only the bright part of the image (the bright arc) corresponding to positive parameters  $\alpha$ . However, Gammie, Shapiro & McKinney [110] showed that black hole spin is usually not very small and could reach 0.7–0.9 (numerical simulations of relativistic magnetohydrodynamic flows give  $a \sim 0.9$ ). Taking into account detections of 106 day cycle in Sgr A\* radio variability seen at 1.3 cm and 2.0 cm by [111] at Very Large Array (VLA), [112] suggested a procedure to evaluate the black hole spin assuming that the variability could be caused by spin induced disk precession.

Moreover, the recent analysis by Aschenbach et al. [113] of periodicity of X-ray flares from the Galactic Center black hole gives an estimate for the spin as high as  $a = 0.9939_{-0.0074}^{+0.0026}$ . Actually, the authors used generalizations of the idea proposed by Melia et al. [114] that the minimum rotation period for Schwarzschild black hole (for an assumed black hole mass of  $2.6 \times 10^6 M_\odot$ ) is about  $P_0 \approx 20$  minutes and could be in the range  $P_0 \in [2.6, 36]$  minutes depending on the black hole spin and prograde and retrograde accretion flows generating the quasi-periodic oscillations. Using this idea and analyzing quasi-periodic variabilities in a infrared band Genzel et al. [99] concluded that the black hole spin should be  $a \sim 0.5$ . However, this conclusion is based on the assumption that the emitting region is located at the marginally stable orbit, therefore if the periodicity is related to the emitting gas motion around the black hole, we should conclude that the black hole spin is  $a \gtrsim 0.5$ . One could also mention that such a determination of the black hole spin is indirect and actual typical frequencies for real accretion flows could be rather different from frequencies considered by the authors. We may summarize by saying that there are indications that the spin of the Galactic Center black hole can be very high, although this problem is not completely solved up to date.

---

<sup>4</sup>An interesting idea to use radio pulsars to test a region near black hole horizon was proposed in [106].

## 8. Discussion

As stated in Section 2, the part of Kerr quasi-rings formed by co-rotating photons is much brighter with respect to the opposite side (i.e. the part of the image formed by counter-rotating photons) and in principle can be detected much more easily. However, even the bright part of the quasi-ring can give information about mass, rotation parameter and inclination angle of the black hole. Of course, if the black hole–observer distance is unknown, the black hole mass can be evaluated in units of the distance. Even if the faint part of image (which is formed by counter-rotating photons) is not detectable, one can try to reconstruct the shape of the total image searching for the best fit of the full image using only the bright part of the image.

Of course, we have such superpower laser (greater than Gigawatt) which Holz & Wheeler [59] wanted to use to investigate a black hole by an active way and, in principle, it is possible to infer the spin parameter and inclination angle by analyzing of mirage shapes formed by retro-photons.

Holz & Wheeler [59] mentioned that the structure of such retro-Macho images will be unresolvable, because of even for very close black holes (say at the age of the solar system), the angular extent of retro-Macho images remain less than a milliarcsecond. If we could assume that this black hole could be at the edge of the solar system. We could not restrict ourselves to speculate on future observational facilities. For example, future Space Interferometry Mission (SIM)<sup>5</sup>, GAIA satellite<sup>6</sup> and FAME<sup>7</sup> could resolve such images, because they will have a sufficient angular resolution for our example (for example, over a narrow field of view SIM could achieve an accuracy of 1  $\mu$ as, a similar accuracy will have GAIA), but unfortunately its limiting magnitude will be about 20 mag (the limiting magnitude for GAIA  $V \sim 20$ ), and since the limiting distance to discover such phenomenon is restricted by Holz & Wheeler [59]

$$D_L = 0.02\text{pc} \times \left[ 10^{(m-30)}/2.5(M/M_\odot)^2 \right]^{1/3}, \quad (11)$$

thus, for SIM limiting magnitude and even for massive black hole ( $M = 10M_\odot$ ), we obtain that such a retro-Macho should be inside of solar system since  $D_L \sim 10^{-4}\text{pc}$ . Therefore, to discover such phenomenon we need instrument like SIM concerning angular resolution, but limiting magnitude should on 10 mag better than SIM. In this case there is a possibility not only to observe such retro-Macho at the the edge of the solar system but also to determine its angular momentum.

## 9. Conclusions

We could summarize that angular resolution of the space RADIOASTRON interferometer will be high enough to resolve radio images around black holes therefore analyzing the shapes of the images one could evaluate the mass and the spin  $a$  for the Kerr black hole inside the Galactic Center and a position angle  $\theta_0$  for a distant observer and as it is clear a position angle could be determined by more simple way for rapidly rotating black holes  $a \sim 1$  (in principle, measuring the mirage shapes we could evaluate mass, inclination angle and spin parameter if we know the distance toward the observed black hole. Otherwise one can only evaluate the spin parameter in units of the black hole mass since even for not very small spin  $a = 0.5$  we have very weak dependence on  $\theta_0$  angle for mirage shapes and hardly ever one could determine  $\theta_0$  angle from the mirage shape analysis. Moreover, we have a chance to evaluate parameters  $a$  and  $\theta$  (for rapidly rotating black holes) if we reconstruct

<sup>5</sup><http://planetquest.jpl.nasa.gov/SIM/>

<sup>6</sup><http://astro.estec.esa.nl/gaia>

<sup>7</sup>The FAME Concept study. Report by Johnson et al. [115] is available at <http://www.usno.navy.mil/FAME/publications>, see also [116].

only bright part of the mirages (bright arcs) corresponding to co-moving photons ( $\alpha > 0$ ). However, for slow rotating black holes  $\alpha \lesssim 0.5$  it would be difficult to evaluate parameters  $a$  and  $\theta$  because we have very slow dependence of mirage shapes on these parameters.

However, there are two kind of difficulties to measure mirage shapes around black holes. First, the luminosity of these images or their parts (arcs) may not be sufficient to being detectable by RADIOASTRON. However, numerical simulations by Falcke, Melia & Agol [60], Melia & Falcke [107] give hope that the luminosity could be not too small at least for arcs of images formed by co-rotating photons ( $\alpha > 0$ ). Second, turbulent plasma could give essential broadening of observed images [104], the longest interferometer baseline  $b_{max} \sim 350000$  km (or for higher orbit  $b_{max} \sim 3.2 \times 10^6$  km) and for this case we have similar to [104] length scale in the scattering medium is  $l = (D_{scattering}/D_{GC}) \times b_{max} \sim 4.4 * 10^3$  km (or  $l = 4.4 \times 10^4$  km for the higher orbit). Thus, the scale could be less or more than the predicted and measured values of the inner scale, which are in the range  $10^2$  to  $10^{5.5}$  km [117, 118, 104], thus the broadening the images could be essential but it is not very easy to calculate it in details for such parameters.

Recent observations of simultaneous X-ray and radio flares at 3 mm, 7 mm, 1.3 cm and 2 cm with the few-hundred second rise/fall timescales gave indirect evidences that X-ray and radio radiation from the close vicinity of Sgr A\* was detected because of that is the most natural interpretation of these flares. However, another interpretations of these flares could not be ruled out and in this case an optical depth for radio waves at 1.3 cm wavelength toward Sgr A\* may be not very small.

Few years ago a possibility to get images of nearby black holes in X-ray band was discussed by White [119], Cash et al. [120], moreover Cash et al. [120] presented a laboratory demonstration of the X-ray interferometer. If the project will be realized, one could get X-ray images of black holes with  $0.1 \times 10^{-6}$  arcsec resolution, thus using this tool one could detect X-ray images around the Galactic Centre and around the black hole in M87 Galaxy.

One could mention also that if the emitting region has a degenerate position with respect to the line of sight (for example, the inclination angle of an accretion disk is  $\gtrsim 85^\circ$ ) strong bending effects found by Matt, Perolla & Stella [121] and analyzed later by Zakharov & Repin [91] do appear. In this case, the mirage shapes will be strongly distorted [88].

In spite of the difficulties of measuring the shapes of images near black holes is so attractive challenge to look at the “faces” of black holes because namely the mirages outline the “faces” and correspond to fully general relativistic description of a region near black hole horizon without any assumption about a specific model for astrophysical processes around black holes (of course we assume that there are sources illuminating black hole surroundings). No doubt that the rapid growth of observational facilities will give a chance to measure the mirage shapes using not only RADIOASTRON facilities but using also other instruments and spectral bands (for example, X-ray interferometer [119]).

Talks on the subject were presented by AFZ at conferences on General Relativity SIGRAV-2004 (Salerno, Italy, see contribution [122]) and ERE-2004 (Madrid, Spain) and authors thank participants for constructive discussion. We also thank profs. J. Miller and L. Rezzolla for fruitful comments after a talk on the subject presented by AFZ at SISSA.

## Acknowledgements

AFZ would like to thank Dipartimento di Fisica Universita di Lecce and INFN, Sezione di Lecce for a hospitality (the work was finished in Lecce). AFZ expresses also his acknowledgement to organizers of the XXVII International Workshop on Fundamental Problems of High Energy Physics and Field Theory “Black holes on Earth and Space”, especially to Academician A.A. Logunov for the kind invitation to present the invited talk at the Workshop.

## References

- [1] J. Greiner, *Cosmic Explosions, Proc. of 10th Annual Astrophysical Conference in Maryland*, (Edited by S.Holt & W.W.Zang,) AIP Conference proceedings, **522**, 2000, 307.
- [2] I.F. Mirabel, *Astrophys. & Space Science*, **276**, 319 (2001).
- [3] I.F. Mirabel and L.F. Rodriguez, *Sky & Telescope*, May, 33 (2002).
- [4] K. Chen and J.P. Halpern, *Astrophys. J.*, **344**, 115 (1998).
- [5] A.C. Fabian, M. Rees, L. Stella and N.E. White, *Mon. Not. Roy. Astron. Soc.*, **238**, 729 (1989).
- [6] G. Matt, G.C. Perola and L. Stella, *Astron. & Astrophys.*, **267**, 643 (1993).
- [7] G. Matt, G.C. Perola, L. Piro L. and L. Stella, *Astron. & Astrophys.*, **257**, 63 (1992).
- [8] G. Matt, G.C. Perola, L. Piro and L. Stella, *Astron. & Astrophys.*, **263**, 453 (1992).
- [9] G. Matt and G.C. Perola, *Mon. Not. Roy. Astron. Soc.*, **259**, 433 (1992).
- [10] G. Matt, A.C. Fabian, R.R. Ross, *Mon. Not. Roy. Astron. Soc.*, **262**, 179 (1993).
- [11] G. Bao, *Astrophys. J.*, **409**, L41 (1993).
- [12] A. Martocchia, G. Matt, V. Karas et al., *Astron. & Astrophys.*, **387**, 215 (2002).
- [13] L.C. Popović, E.C. Mediavilla, J.A. Munoz, *Astron. & Astrophys.*, **378**, 295 (2001).
- [14] L.C. Popović, E.G. Mediavilla, P. Jovanović et al. *Astron. & Astrophys.*, **398**, 975 (2003).
- [15] A.F. Zakharov, L.Č. Popović and P. Jovanović, *Astron. & Astrophys.*, **420**, 881-888 (2004).
- [16] A.F. Zakharov, L.Č. Popović and P. Jovanović, in *Proc. of the XXIXth Rencontres de Moriond "Cosmology: Exploring the Universe"*, edited by J. Dumarchez and J. Tran Thanh Van, The GIOI publishers, 2004, (see also <http://moriond.in2p3.fr/J04/proceedingsm04.html>, astro-ph/0406417).
- [17] A.F. Zakharov, L.Č. Popović and P. Jovanović, in *Proc. of the 225 IAU Symposium "Impact of Gravitational Lensing on Cosmology"*, edited by G. Meylan and J. Mellier, The Cambridge University Press, 2004; astro-ph/0410378.
- [18] A.C. Fabian, K. Nandra, C. S. Reynolds et al., *Mon. Not. Roy. Astron. Soc.*, **277**, L11 (1995).
- [19] Y. Tanaka, K. Nandra, A.C. Fabian et al., *Nature*, **375**, 659 (1995).
- [20] K. Nandra, I.M. George, R.F. Mushotzky et al.: *Astrophys. J.*, **476**, 70 (1997).
- [21] K. Nandra, I.M. George, R.F. Mushotzky et al., *Astrophys. J.*, **477**, 602 (1997).
- [22] A. Malizia, L. Bassani, J.B. Stephen et al. 1997, *Astrophys. J. Suppl.*, **113**, 311 (1997).
- [23] R.M. Sambruna, I.M. George, R.F. Mushotsky et al., *Astrophys. J.*, **495**, 749 (1998).
- [24] T. Yaqoob, I.M. George, K. Nandra et al., 2001, *Astrophys. J.*, **546**, 759 (2001).
- [25] P.M. Ogle, H.L. Marshall, J.C. Lee et al., 2000, *Astrophys. J.*, **545**, L81 (2000).

- [26] J.M. Miller, A.C. Fabian, R. Wijnands et al., 2002, *Astrophys. J.*, **570**, L69 (2002).
- [27] A.C. Fabian, K. Iwazawa, C.S. Reynolds and A.J. Young, *Publ. Astron. Soc. Pac.*, **112**, 1145 (2000).
- [28] Y. Kojima, *Mon. Not. Roy. Astron. Soc.*, **250**, 629 (1991).
- [29] A. Laor, *Astrophys. J.*, **376**, 90 (1991).
- [30] G. Bao and Z. Stuchlik, *Astrophys. J.*, **400**, 163 (1992).
- [31] G. Bao, P. Hadrava and E. Ostgaard, *Astrophys. J.*, **435**, 55 (1994).
- [32] B.C. Bromley, K. Chen and W.A. Miller, *Astrophys. J.*, **475**, 57 (1997).
- [33] C. Fanton, M. Calvani, F. de Felice and A. Cadez, *Publ. Astron. Soc. Japan*, **49**, 159 (1997).
- [34] V.I. Pariev and B.C. Bromley, *Proc. of the 8-th Annual October Astrophysics Conference in Maryland "Accretion Processes in Astrophysical Systems: Some Like it Hot!" College Park, MD, October 1997* (Edited by Stephen S. Holt and Timothy R. Kallman), AIP Conference Proceedings **431**, 1997, p. 273.
- [35] V.I. Pariev and B.C. Bromley, *Astrophys. J.*, **508**, 590 (1998).
- [36] V.I. Pariev, B.C. Bromley and W.A. Miller, *Astrophys. J.*, **547**, 649 (2001).
- [37] M. Ruszkowski, *Mon. Not. Roy. Astron. Soc.*, **315**, 1 (2000).
- [38] Z. Ma, *Chin. Phys. Lett.*, **19**, 1537 (2002).
- [39] A.F. Zakharov, *Soviet Astron.*, **35**, 30 (1991).
- [40] A.F. Zakharov, *Preprint MPA 755* (1993).
- [41] A.F. Zakharov, *Mon. Not. Roy. Astron. Soc.*, **269**, 283 (1994).
- [42] A.F. Zakharov and S.V. Repin, *Astronomy Reports*, **43**, 705 (1999).
- [43] A.F. Zakharov and S.V. Repin, *Astronomy Reports*, **46**, 360 (2002).
- [44] A.F. Zakharov and S.V. Repin, in *Proc. of the XXIV International Workshop on High Energy Physics and Field Theory "Fundamental Problems of High Energy Physics and Field Theory"*, edited by V.A. Petrov, State Research Center of Russia – Institute for High Energy Physics, Protvino, 2001, p. 99.
- [45] A.F. Zakharov and S.V. Repin, in *Proc. of the Eleven Workshop on General Relativity and Gravitation in Japan*, edited by J. Koga, T. Nakamura, K. Maeda, K. Tomita, Waseda University, Tokyo, 2002, p. 68.
- [46] A.F. Zakharov and S.V. Repin, in *Proc. of the Workshop "XEUS - studying the evolution of the hot Universe"*, edited by G. Hasinger, Th. Boller, A.N. Parmar, MPE Report 281, 2003, p. 339.
- [47] A.F. Zakharov and S.V. Repin, in *Proc. of the XXXVIIth Rencontres de Moriond "The Gamma-ray Universe"*, edited by A. Goldwurm, D.N. Neumann and J. Tran Thanh Van, The GIOI publishers, 2002, p. 203.

- [48] A.F. Zakharov and S.V. Repin, in *Proc. of the Tenth Lomonosov Conference on Elementary Particle Physics "Frontiers of Particle Physics"*, edited by A.I. Studenikin, World Scientific Publishing House, Singapore, 2003, p. 278.
- [49] A.F. Zakharov and S.V. Repin, in *Proc. of the 214th Symposium on "High Energy Processes and Phenomena in Astrophysics"*, edited by X.D.Li, V. Trimble, Z.R. Wang, Astronomical Society of the Pacific, 2003, p. 97.
- [50] A.F. Zakharov and S.V. Repin, in *Proceedings of the Third International Sakharov Conference on Physics*, volume I, edited by A. Semikhatov, M. Vasiliev and V.Zaikin, Scientific World, 2003, p. 503.
- [51] A.F. Zakharov and S.V. Repin, in *Proceedings of the International Conference "I.Ya. Pomeranchuk and physics at the turn of centuries"*, World Scientific Publishing House, Singapore, 2004, p. 159.
- [52] A.F. Zakharov and S.V. Repin, *Astron. & Astrophys.*, **406**, 7 (2003).
- [53] A.F. Zakharov and S.V. Repin, *Astronomy Reports*, **47**, 733 (2003).
- [54] A.F. Zakharov and S.V. Repin, *Advances in Space Res.* (accepted).
- [55] A.F. Zakharov, N.S. Kardashev, V.N. Lukash and S.V. Repin, *Mon. Not. Roy. Astron. Soc.*, **342**, 1325 (2003).
- [56] A.F. Zakharov, *Publ. Astron. Obs. of Belgrade.*, **76**, 147 (2003).
- [57] A.F. Zakharov, *Publ. Astron. Obs. of Belgrade.*, **76**, 147 (2003).
- [58] A.F. Zakharov, Lecture at 22nd Summer School and International Symposium on the Physics of Ionized Gases, Bajina Basta, Serbia, 23- 27 August 2004, to be published in AIP conference proceedings.
- [59] D. Holz and J.A. Wheeler, *Astrophys. J.*, **578**, 330 (2002).
- [60] H. Falcke, F. Melia, E. Agol, *Astrophys. J.*, **528**, L13 (2000).
- [61] S. Frittelli, T.P. Kling & E.T. Newman, *Phys. Rev. D*, **61**, 064021(2000).
- [62] K.S. Virbhadra & G.F.R. Ellis, *PRD*, **62**, 084003 (2000).
- [63] K.S. Virbhadra & G.F.R. Ellis, *Phys. Rev. D*, **65**, 103004 (2002).
- [64] I. Ciufolini & F. Ricci, *Class. Quant. Grav.*, **19**, 3863 (2002).
- [65] I. Ciufolini & F. Ricci, gr-qc/0301030 (2003).
- [66] V. Bozza, *Phys. Rev. D*, **66**, 103001 (2002).
- [67] V. Bozza, *Phys. Rev. D*, **67**, 103006 (2003).
- [68] V. Bozza & L. Mancini, *Class. Quant. Grav.*, **36**, 435 (2004).
- [69] V. Bozza & L. Mancini, astro-ph/0404526 (2004).
- [70] E.F. Eiroa, G.E. Romero & D.F. Torres, *Phys. Rev. D*, **66**, 024010 (2002).

- [71] E.F. Eiroa & D.F. Torres, *Phys. Rev. D*, **69**, 063004 (2004).
- [72] M. Sereno, *Mon. Not. Roy. Astron. Soc.*, **344**, 942 (2003).
- [73] M. Sereno, *Phys. Rev. D*, **69**, 023002 (2004).
- [74] P. Young, *Phys. Rev. D*, **14**, 3281 (1976).
- [75] S. Chandrasekhar, *The Mathematical Theory of Black Holes*. Clarendon Press, Oxford, 1983.
- [76] A.F. Zakharov, *Sov. Phys. - Journ. Experim. and Theor. Phys.*, **64**, 1 (1986).
- [77] A.F. Zakharov, *Sov. Phys. - Journ. Experimental and Theoretical Phys.*, **68**, 217 (1989).
- [78] F. De Paolis, A. Geralico, G. Ingrosso, A.A. Nucita, *Astron. & Astrophys.*, **409**, 804 (2003).
- [79] F. De Paolis, A. Geralico, G. Ingrosso, A.A. Nucita, A. Qadir, *Astron. & Astrophys.*, **415**, 1 (2004).
- [80] J.-P. Luminet, *Astron. & Astrophys.*, **75**, 228 (1979).
- [81] A. Beloborodov, *Astrophys. J.*, **566**, L85 (2002).
- [82] P.T. Mutka & P. Mähönen, *Astrophys. J.*, **581**, 1328 (2002).
- [83] M. Salgado, S. Bonazzola, E. Gourgoulhon & P. Haensel, *Astron. & Astrophys. Suppl.*, **108**, 455 (1994).
- [84] M. Salgado, S. Bonazzola, E. Gourgoulhon & P. Haensel, *Astron. & Astrophys.*, **291**, 155 (1994).
- [85] B. Carter, *Phys. Rev.*, **174**, 1559 (1968).
- [86] A.F. Zakharov, *Preprint ITEP 44-91* (1991).
- [87] K.P. Rauch and R. D. Blandford, *Astrophys. J.*, **421**, 46 (1994).
- [88] K. Beckwith & C. Done, 2004, *Mon. Not. Roy. Astron. Soc.*(accepted); astro-ph/0402199.
- [89] A.F. Zakharov, In *17th Texas Symposium on Relativistic Astrophysics*, Ann. NY Academy of Sciences, 1995, **759**, 550.
- [90] A.F. Zakharov and S.V. Repin, in *Proc. of the Eleven Workshop on General Relativity and Gravitation in Japan*, eds. J. Koga, T. Nakamura, K. Maeda, K. Tomita (eds) Waseda University, Tokyo, 2002, p. 68.
- [91] A.F. Zakharov, S.V. Repin, *Astron. & Astrophys.*, **406**, 7 (2003).
- [92] A.F. Zakharov and S.V. Repin, in *XEUS - studying the evolution of the hot universe*, eds G. Hasinger, Th. Boller, and A.N. Parmer, MPE Report 281, 2003, p. 339.
- [93] A.F. Zakharov and S.V. Repin, *Astron. Rep.*, **47**, 733 (2003).
- [94] S. Sawada-Sato, in *Proceedings of the VSOP Symposium*, held at the Institute of Space and Astronautical Science, Sagami-hara, Kanagawa, Japan, January 19 - 21, 2000, Eds.: H. Hirabayashi, P.G. Edwards, and D.W. Murphy, Published by the Institute of Space and Astronautical Science, 2000, p. 317.



- [95] M. Honma, *Publ. Astron. Soc. Japan*, **53**, 233 (2001).
- [96] M. Honma & T. Kurayama, *Astrophys. J.*, **568**, 717 (2002).
- [97] K.Y. Lo, Zh.-Q. Shen, J.-H. Zhao, P.T.P. Ho, *Astrophys. J. Lett.*, **508**, L61 (1998).
- [98] K.Y. Lo, Zh.-Q. Shen, J.-H. Zhao, P.T.P. Ho, in *The Central Parsecs of the Galaxy*, Eds. H. Falcke, A. Cotera, W.J. Duschl, F. Melia, M.J. Rieke, ASP Conference Series, 1999, p. 317.
- [99] R. Genzel, R. Schödel, T. Ott et al., *Nature*, **425**, 934 (2003).
- [100] A.M. Ghez et al., *Astrophys. J. Lett.*, **601**, L159 (2004).
- [101] F.K. Baganoff et al., *Nature*, **413**, 45 (2003).
- [102] F.C. Bower, H. Falcke, R.J. Sault & D.C. Backer, *Astrophys. J.*, **571**, 843 (2002).
- [103] F.C. Bower, M.C.H. Wright, H. Falcke & D.C. Backer, *Astrophys. J.*, **588**, 331 (2003).
- [104] F.C. Bower, H. Falcke, R.M. Herrnstein et al. 2004, *Scienceexpress*, [www.scienceexpress.org/1](http://www.scienceexpress.org/1) April 2004/.
- [105] R. Narayan, *Nature*, **425**, 908 (2003).
- [106] E. Phahl & A. Loeb, astro-ph/0309744 (2003).
- [107] F. Melia & H. Falcke, *Annual Rev. Astron. & Astrophys.*, **39**, 309 (2001).
- [108] A.M. Ghez et al., *Astrophys. J. Lett.*, **586**, L127 (2003).
- [109] R. Schödel et al., *Astrophys. J.*, **596**, 1015 (2003).
- [110] C.F. Gammie, S. Shapiro & J.C. McKinney, *Astrophys. J.*, **602**, 312 (2004).
- [111] J.H. Zhao, G.C. Bower & W.M. Goss, *Astrophys. J.*, **547**, L29 (2001).
- [112] S. Liu & F. Melia, *Astrophys. J.*, **573**, L23 (2002).
- [113] B. Aschenbach, N. Grosso, D. Porquet & P. Predehl P., *Astron. & Astrophys.*, 417, 71 (2004).
- [114] F. Melia, B. Bromley, S. Liu. & C. Walker, *Astrophys. J.*, **554**, L37 (2001).
- [115] K.J. Johnson et al., *FAME Concept Study Report*, (Washington DC: USNO, 1999).
- [116] S. Salim, A. Gould & R.P. Olling, *Astrophys. J.*, **573**, 631 (2002).
- [117] P.N. Wilkinson, R. Narayan, & R.E. Spencer, *Mon. Not. Roy. Astron. Soc.* **238**, 963 (1994).
- [118] K.M. Desai & A.L. Fey, *Astrophys. J. Suppl.*, **133**, 395 (2001).
- [119] N. White, *Nature*, **407**, 146 (2000).
- [120] W. Cash, A. Shipley, S. Osterman, M. Joy, *Nature*, **407**, 160 (2000).
- [121] G. Matt, G.C. Perolla & L. Stella, *Astron. & Astrophys.*, **267**, 643 (1993).
- [122] A.F. Zakharov, A.A. Nucita, F. DePaolis, G. Ingrosso, in *Proc. at SIGRAV-2004 conference on General Relativity*, Salerno, Italy, 13-16 September 2004, to be published in AIP conference proceedings.